

LARINO 3 WAY FILTER TAP

Installation and user manual

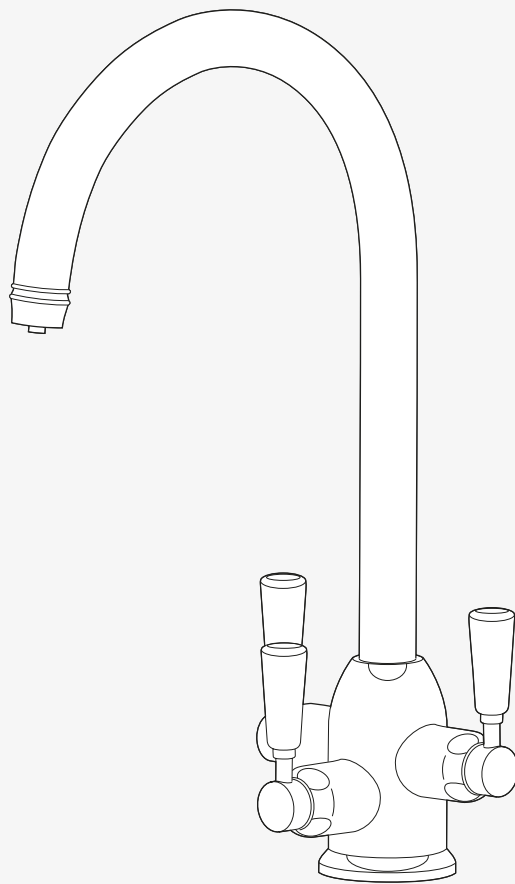

*Make
it
Wonderful*

FRANKE

ABOUT THIS MANUAL

- ▷ Carefully read the user manual before using the device.
- ▷ Keep the user manual.
- ▷ Use the device described in this user manual only according to the intended use.

Symbol Meaning

- | Symbol | Meaning |
|--------|--|
| ▷ | Actions in safety and warning notes to avoid injury or damage. |
| ▶ | Action step. Specifies an action to be done. |
| ■ | Result. Result of one or more action steps. |

SAFETY INFORMATION

These hints have been prepared for your guidance, you must exercise due care at all times. We do not accept responsibility for any problems that may occur through incorrect installation.

Important:

- ▷ The tap is designed for non-professional use in the household; do not modify its characteristics.
- ▷ Always demand original spare parts.

TECHNICAL DATA

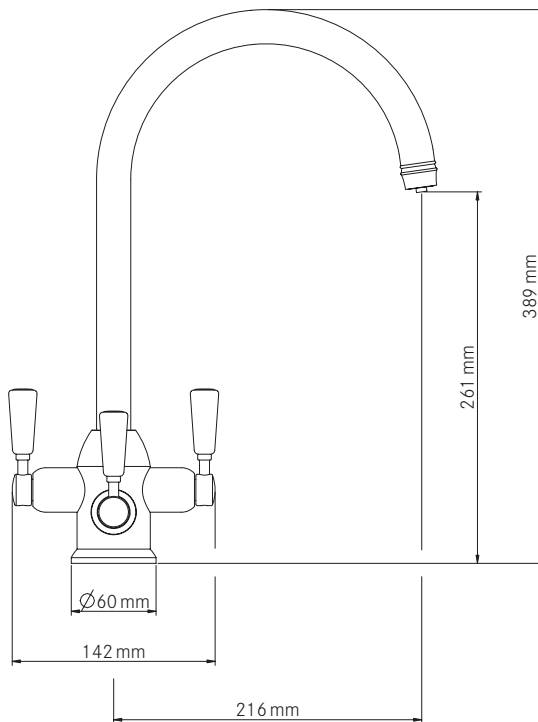

Operating data	Value	
Water pressure (min.)	1 bar	14.5 PSI
Water pressure (max.)	5 bar	75 PSI
Hot water temperature (ideal)	65°C	149°F
Hot water temperature (max.)	70°C	158°F

Note: If these temperatures or water pressures are exceeded damage to the tap can result.

A pressure reducing valve may be required to be fitted in high water pressure situations.

Note: If for any reason the spout is removed from the tap, care must be taken when reinserting the spout into the body to ensure that the Grub Screw (SP3668) is located in the split of the white PTFE ring.

CLEANING AND MAINTENANCE

- ▶ To maintain the appearance of this fitting, ensure it is cleaned only using a clean, soft damp cloth.
- ▶ A solution of warm water and mild liquid detergent may be used where necessary, and then the fitting rinsed thoroughly.
- ▷ Abrasive cleaners or acidic cleaners **MUST NOT BE USED** under any circumstances.
- ▷ Avoid contact with all solvents.

INSTALLATION

Connecting the FilterFlow

Please refer to the diagram and instructions.

- ▷ Before installing the new mixer it is essential that you thoroughly flush through the supply pipes in order to remove any remaining swarf, solder or other impurities.
 - Failure to carry out this simple procedure could cause problems or damage to the workings of the mixer.
- ▷ Having first checked all new connections, turn on the mains stopcock, close all taps except the new mixer and as the system starts to refill check for leaks. Once you have satisfied yourself that there are no leaks, switch on the water heating.

Preparation

- ▷ First shut off your water heating system then, with your mains stopcock closed.
- ▷ Open the lowest hot and cold taps in the house and allow to run until the cold storage tank and pipes are empty.

(The hot water storage cylinder always remains full).

Installation

- ▶ First screw the threaded stud into the mixer body.
- ▶ Screw the tails into the mixer body and fully hand tighten.
- ▶ After making any necessary alterations to existing pipework, pass the plinth over the tails and fit in position. The shaped upstand on the plinth will locate in the tap body and the 'O' ring should be placed in the recess to make a seal with the sink.

- ▶ When the tap is in position (with the cold side on the right when viewed from the front) slide the nylon bracing plate up to the underside of the sink together with the retaining plate, and secure by screwing the fixing nut finger tight.
- ▶ Check that the mixer body and plinth are correctly positioned and fully tighten fixing nut. It is recommended that 15 mm x 15 mm compression fittings be used to connect mixer to supply pipes.
 - Cold is connected to the right and hot on the left when viewed from the front.

Connecting the FilterFlow

Locate the 3/8" diameter stem at the base of your Franke FilterFlow filter tap.

- ▶ Wet the stem with a little water
- ▶ Select the remaining braided hose (B) with the grey plastic push fit connector (A) attached to the free end.
- ▶ Engage the push fit connector on the tail and push it firmly on the stem.

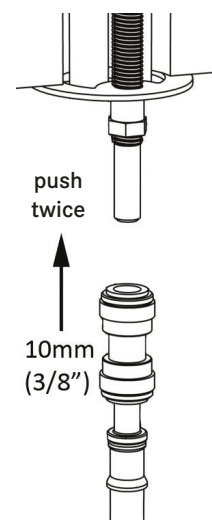

Important

- ▷ Initial resistance will be felt as the internal 'O' seal is engaged – continue to push the connector past the seal to the final stop.
- ▷ The connector should push on the stem 10 mm (3/8").
 - Failure to fully engage the connector may result in subsequent failure of the joint.

GUARANTEE

Your Franke FilterFlow tap has been manufactured to the high standard you would expect of any Franke product but in the unlikely event that you should experience any defect in the materials or workmanship within one year of purchase*, we will replace the faulty part free of charge. This is provided the mixer has only been used for normal domestic purposes in the UK and that the care, installation and maintenance instructions have been observed.

You should also retain your dated invoice as proof of purchase to validate any claims under our guarantee.

*Normal wear and tear is excluded from the guarantee.

This one year guarantee is extended to five years in the case of the valve mechanisms.

Decorative surface finishes are guaranteed for one year from the date of purchase provided our advice concerning care has been observed and no scouring agents have been used.

Scuffs and scratches caused by improper installation or accidental damage are not covered by this guarantee. Neither are slight shade variations or any damage or defect caused by incorrect installation or abuse of the fitting.

PARTS LIST

Available Finish

Larino Classic	120.0486.827
----------------	--------------

Spare Parts

FUN number	Part name	Part code
1	SPOUT SILKSTEEL	SP4225 SS
2	AERATOR SILKSTEEL	SP3628 SS
3	O-RING KIT	SP3668
4	HOT HANDLE SILKSTEEL	SP4231-H SS
5	COLD HANDLE SILKSTEEL	SP4231-C SS
6	FILTER HANDLE SILKSTEEL	SP4231-F SS
7	VALVE COVER SILKSTEEL	SP3667 SS
8	HOT VALVE	SP3561-H
9	COLD VALVE	SP3561-C
10	PLINTH FRANKE SILKSTEEL	SP3260#056F SS
11	FIXING KIT	SP3622
12	FLEXI-TAILS	SP4156
13	KEY FOR FIXING NUT	SP3619

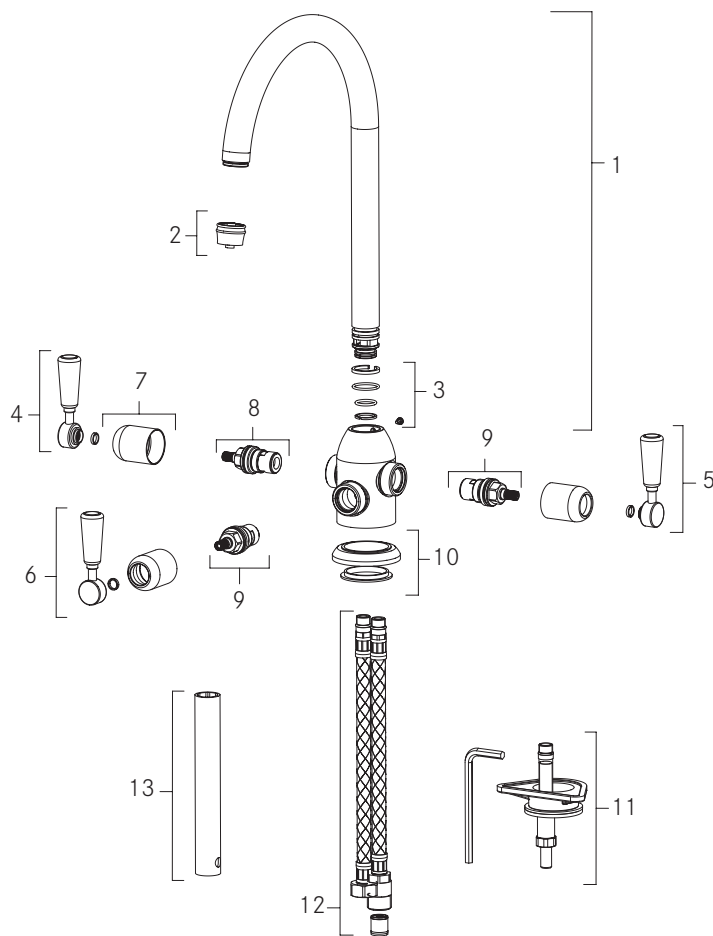

SUPPORT

For spare parts, servicing or any other queries, visit www.franke.co.uk

Franke UK Limited

West Park, MIOC
Styal Road
Manchester
M22 5WB
Tel: +44 (0)161 436 6280
Fax: +44 (0)161 436 2180
Email info.uk@franke.com
www.franke.co.uk

